

EXTERNAL ANTENNA RP-SMA



The units with an external connector have been designed for those situations where the display has been installed in a place with a poor RF communication signal. If the display must be installed in a metal box or similar, it will be necessary to use a unit with external antenna. The units with an external antenna connector (see references) have the antenna included with a 3-meter cable and magnet fixation. The antenna connector is at the bottom of the display where the glands are.



REFERENCES AND ACCESSORIES

References

0106030411	WM44-EV011 V3 IP65 24Vdc
0106030412	WM44-EV011 V3 IP65 230Vac

Wireless (wind sensor and emitter included)

0103012003	SET ANEMO4403 V3 + RF MODULE V3 FB + WM44-EV011 V3 RF IP65 24Vdc
0103012004	SET ANEMO4403 V3 + RF MODULE V3 FB + WM44-EV011 V3 RF IP65 230Vac
0103012007	SET ANEMO4403 V3 + RF MODULE V3 F/SLB + WM44-EV011 V3 RF IP65 24Vdc
0103012008	SET ANEMO4403 V3 + RF MODULE V3 F/SLB + WM44-EV011 V3 RF IP65 230Vac
0103012011 ¹	SET ANEMO4403 V3 + RF MODULE V3 FB + WM44-EV011 V3 RF RP-SMA IP65 24Vdc
0103012012 ¹	SET ANEMO4403 V3 + RF MODULE V3 FB + WM44-EV011 V3 RF RP-SMA IP65 230Vac
0103012015 ¹	SET ANEMO4403 V3 + RF MODULE V3 F/SLB + WM44-EV011 V3 RF RP-SMA IP65 24Vdc
0103012016 ¹	SET ANEMO4403 V3 + RF MODULE V3 F/SLB + WM44-EV011 V3 RF RP-SMA IP65 230Vac

Displays for add to RF Sets

0106030801	WM44-P V3 RF 24Vdc
0106030802	WM44-P V3 RF 230Vac
0106030805 ¹	WM44-P V3 RF RP-SMA 24Vdc
0106030806 ¹	WM44-P V3 RF RP-SMA 230Vac
0106030413	WM44-EV011 V3 RF IP65 24Vdc
0106030414	WM44-EV011 V3 RF IP65 230Vac
0106030415 ¹	WM44-EV011 V3 RF RP-SMA IP65 24Vdc
0106030416 ¹	WM44-EV011 V3 RF RP-SMA IP65 230Vac

¹References with external antenna connector (antenna included in reference)

Wind Sensors and Wind Vanes

Pulses output anemometers

0103010801	ANEMO4403 V3 PULSES OUTPUT M8 LATERAL
0103010802	ANEMO4403 V3 PULSES OUTPUT M8 UNDERSIDE
0103010804	ANEMO4403 V3 PULSES OUTPUT 2,5m CABLE
0103010806	ANEMO4403 V3 PULSES OUTPUT

4-20mA Analog output anemometers

0103011001	ANEMO4403 V3 4-20mA OUTPUT 120 km/h M8 LATERAL
0103011002	ANEMO4403 V3 4-20mA OUTPUT 180 km/h M8 LATERAL
0103011003	ANEMO4403 V3 4-20mA OUTPUT 120 km/h 20m CABLE
0103011004	ANEMO4403 V3 4-20mA OUTPUT 180 km/h 20m CABLE
0103011005	ANEMO4403 V3 4-20mA OUTPUT 120 km/h TIME 2s 20m CABLE

Wind Vanes

0103010711	WV4403 4-20mA OUTPUT M12 UNDERSIDE
0103010712	WV4403 4-20mA OUTPUT 2,5m CABLE
0103010713	WV4403 4-20mA OUTPUT 20m CABLE

Heated versions, view datasheet:
 - ANEMO5H25 V3 PULSES OUTPUT
 - ANEMO5H25 V3 4-20mA OUTPUT
 - WV5H25 4-20mA OUTPUT

¹For other references, please contact us.



Electronics at the service of industry

WM44-EV011 V3

WM44 V3 range of IED Electronics.
 Wind speed and direction display for outdoors. IP65.

WM44 V3 is a wind speed and direction display for outdoors with 2 alarm relays. Possibility of connecting wind sensors with a frequency or a 4-20 mA analogue output. It has a power output for sensors.

For outdoor/indoor installation (IP65)
 Backlighted Graphic Liquid Crystal Display
 Adjustable wind speed alarms
 4-20mA analogue output

FEATURES

Alarms

The alarm is triggered when the wind speed reaches or exceeds the programmed value. It includes a delay, configurable by keyboard, to prevent the alarm from being triggered by gusts of wind. The alarm is deactivated when the wind speed drops below the programmed value. It also has a configurable delay to prevent the alarm from being deactivated by temporary periods of low-intensity wind.

The activation of ALARM2 deactivates ALARM1. When ALARM2 is triggered, the reading will blink to warn about the danger.

Alarms configuration: Trigger values, polarity, intermittent or continuous alarm, alarm latching (only ALARM2)

Alarms outputs: Relays. Contacts "NO" and "NC" (ALARM1), contact "NO" (ALARM2). Dry relay contacts.

User Default setting

The setting can be saved as "User Default setting" and can be retrieved when necessary P00 - (4). If no configuration has been saved, the factory configuration can be reset with this process.

Register of minimum and maximum wind values.

WM44-EV011 automatically records the minimum and the maximum wind speed values. Press "ENTER" to see the minimum value and press it again to see the maximum one. After 3 seconds it displays the current screen again.

To reset the minimum and the maximum values press "ESCAPE" for 2 seconds.

Note: Both values are deleted when the power supply is cut off.

PROGRAMMING

To enter the "Programming Mode" press simultaneously "ENTER" and "ESCAPE" for 2 seconds.

BUTTON FUNCTIONS IN PROGRAM MODE

Button	Function
UP	Increases the program steps (P00, P01...), as well as the options or values to be programmed.
DOWN	Decreases the program steps and the options or values to be programmed.
ENTER	Enters the program step which validates options and values and exits the program step.
ESC	Returns to the program steps.

PROGRAM STEPS

P00	(1) Exit program mode without saving data, (2) Exit program mode saving data, (3) Exit program mode saving data as "preset user configuration", (4) Exit program recovering "preset user configuration" data by pressing "ENTER" for more than 10sec. [0]
P01	Wind sensor selection. (0) Only anemometer, (1) Only wind vane, (2) Anemometer + wind vane. [0]
P02	Anemometer input selection. Only for P01 = 0 and P01 = 2. (0) Pulse input, (1) 4-20mA Input (2) RF Anemo4403. [0]
P03	Wind vane input Selection. Only for P01 = 1 and P01 = 2. (0) 4-20mA Input, (1) RF WV4403. [0]
P04	(0) Programming in km / h, (1) Programming in mph, (2) Programming in m / s. [0]
P05	Only for P02 = 0. Reference speed displayed (1-999). [100]
P06	Only for P02 = 0 Frequency in Hz necessary to visualize the programmed value in P05. [121]
P07	Only for P02 = 0. Speed/Hz ratio offset [3]
P08	Only for P02 = 1. Selection of full scale (0) 120km/h, (1) 180 km/h [0]
P09	Only for P03 = 0. Selection of full scale in degrees (0-359). [0]
P10	ALARM1. (0) Disabled, (1) OUT1 NO contact switches to NC (2) OUT1 NC contact switches to NO [1]
P11	ALARM1. Trigger value (1-999). [50]
P12	ALARM1. Mode. (0) Continuous mode, (1) Intermittent mode. [1]
P13	ALARM1. Only intermittently (P12 = 1). Alarm ON time in tenths of seconds (1-99). [10]
P14	ALARM1. Only intermittently (P12 = 1). Alarm OFF time in tenths of seconds (1-99). [50]
P15	ALARM1. Activation delay in seconds (0-999). [2]
P16	ALARM1. Deactivation delay in seconds (0-999). [5]
P17	ALARM2. (0) Disabled, (1) OUT2 NO contact switches to NC, (2) OUT2 NC contact switches to NO. [1]
P18	ALARM 2. Same as P11 ALARM1. [70] (when this value is exceeded, the displayed value blinks as a warning).
P19	ALARM2. Same as ALARM1 P12. [0]
P20	ALARM2. Same as ALARM1 P13. [5]
P21	ALARM2. Same as ALARM1 P14. [5]
P22	ALARM2. Activation delay in seconds (0-999). [2]
P23	ALARM2. Deactivation delay in seconds (0-999). [5]
P24	ALARM2. Configuration latching. (0) Non-latching, (1) Latching [0] (Power off to release).
P25	Analogue output configuration. (0) Disabled, (1) Proportional to the wind speed, (2) proportional to the wind direction. [0]
P26	Value of wind speed / direction corresponding to the maximum analogue output (20mA) [120]
P27	Only for P02 = 2 and P03 = 1. Timeout data reception Anemo4403 RF and WM4403 RF. Time, 5-99 seconds. [12] <i>NOTE: Timeout should not be less than 9sec in battery powered devices (Anemo4403 RF BAT and WV4403 RF BAT).</i>
P28	Alarm status with timeout error. (0) No active alarm (1) ALARM1 active, (2) ALARM2 active. [2]

Note:

- In bold and between brackets **[x]**, the factory settings.

TECHNICAL SPECIFICATIONS

Electrical features	
Power supply	230 Vac, 50-60 Hz 24 Vdc
Power consumption	< 3.5 VA @ 230 Vac < 3 W @ 24 Vdc
Inputs	
Type of input signal	Frequency, analogue (4-20mA) or RF
RF connectivity	IEEE 802.15.4. ISM 2.4GHz
Outputs	
Power output for sensors	15 Vdc
Analogue output	4-20 mA
Max. connectable impedance	500 Ohm
Analogue output resolution	10 bit
Analogue output accuracy	1,5%
Alarm relays	250 Vac, 8A

Display

Display	Backlighted liquid crystal display 128x64 pix
Wind speed	3 digits. Units to choose from: km/h, mph and m/s
Wind direction	3 digits. Indication in degrees and cardinal points

General features

Enclosure material	Polycarbonate
Weight	250 g
Storage temperature	-35 °C +70 °C
Working temperature	-20 °C +70 °C
IP protection	IP65
EMC	EN 61000-6-2:2001 EN 55022:2001, Class B

DIMENSIONS

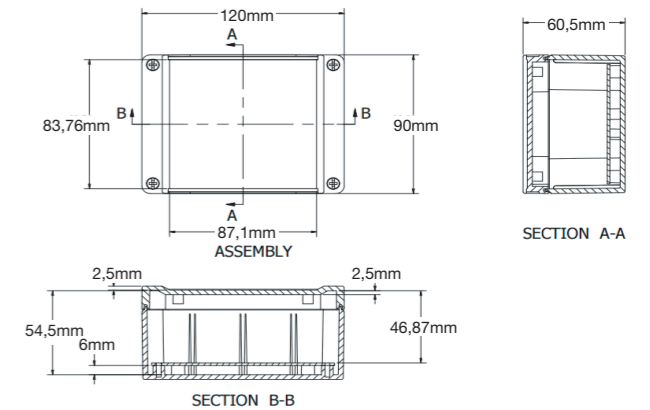

CONNECTION

To make the connection is necessary to open the device enclosure. The internal terminal blocks have all the necessary indications to make such connection.

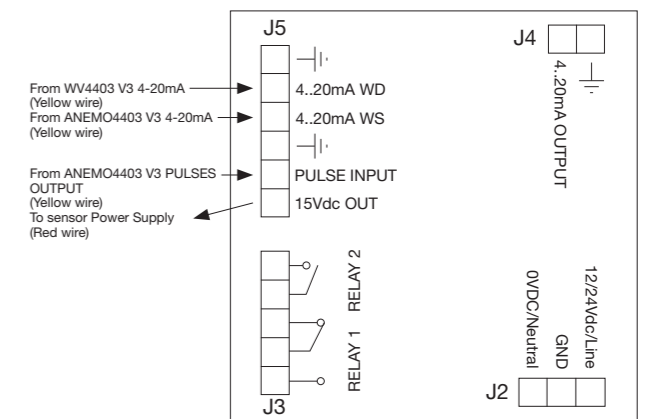

J3: Output relays connector. Configuration through P09 y P16.

J4: Analogue output connector. Configuration through P24 y P25.

J5: Wind sensors connector. Configuration through P01, P02 y P03.*

*Note: When using WM44-EV011 with two wind sensors, a T-Box (IED electronics ref. 0106030405) is required.

