

REFERENCES AND ACCESSORIES

References	Anemometer
ANTC_V3.1_INOX	USCITA RS485 MODBUS

Optional	Description
ANTC_V_R	Self-regulating heater integrated into the body
CAV_SCH5x0,5	Connection cable for anemometer with heater supplied in the required length

RS485 MODBUS

Thanks to the MODBUS protocol, installation and data display is even easier, in particular:

- Immediate integration into various supervisory, control and automation systems
- Open specifications that do not require hardware constraints
- Reliable communication between automation devices
- Interoperability between devices from different manufacturers

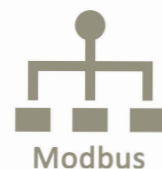

Industrial design
Pulse frequency output or analog in mA or V
Range up to 200 Km/h.
Rotating transducer mounted on double ball bearing
Male connector M12
Compatibility with PLC and / or market electronics

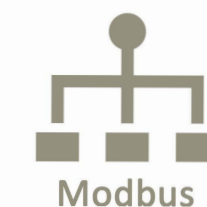

ANTC V3.1-STAINLESS STEEL AISI 316

Anemometer cups with multiple outputs for industry-standard ACCREDIA certificate

The ANTC series has been designed and built for industrial applications, in particular:

- Surveys for wind towers
- Historical analysis data logger
- Wind threshold control for photovoltaic sails and solar trackers

However, it is used in any sector where reliable, robust and precise product characteristics are required.

The body of the rotor is machined STAINLESS STEEL AISI316 with stainless steel support. The head rotates on ball bearings. The cups are made of nylon shock-absorbent and easily interchangeable. It also features a convenient connector for connection. The count rate is via optical transducer, a digital encoder with 12 pulses per revolution.

EACH TRANSDUCER IS TESTED IN A WIND TUNNEL AND EQUIPPED WITH A CALIBRATION CERTIFICATE. On request, it's possible a periodic check and product calibration.

NUOVACEVA
AUTOMATION

NUOVA CEVA AUTOMATION S.R.L.
via Don Signini 43 - 28010 - Briga Novarese - NO - ITALY
Phone +39 0322 93574
info@nuovaceva.it www.nuovaceva.it



APPLICATION

The ANTC Stainless Steel Anemometer is particularly suitable for highly corrosive environments or in saline environments, therefore on port cranes or by ship. It can be used, also, in the following sectors:

- Cranes and Mobile Cranes
- Buildings and general structures
- Photovoltaic solar trackers
- Wind turbines
- Weather Stations
- Irrigation systems
- Automated greenhouses
- Cable cars for ski plants
- Cannons snow
- Telescopic cranes
- Platforms self-mounting
- Structures for playgrounds
- Ornamental fountains
- Pressostatic structures
- Highway tunnels and viaducts

DIMENSIONS

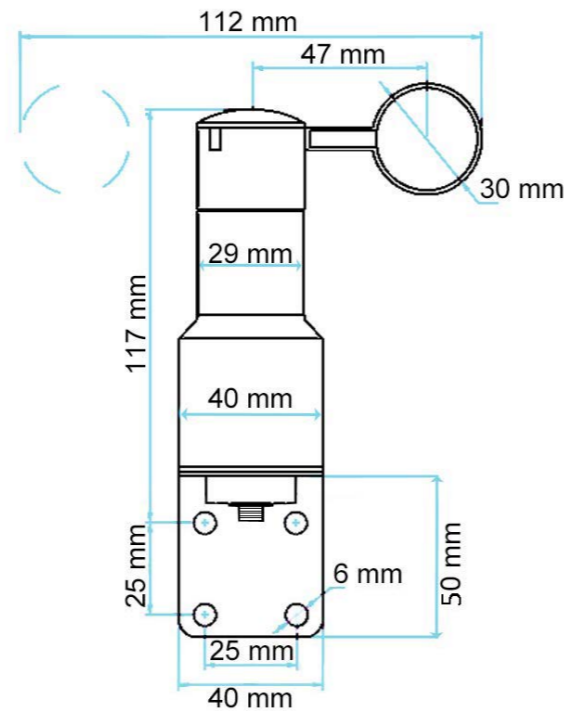

TECHNICAL FEATURES

Electric Features	
Power Supply	10...30 Vdc
Max. Current	50 mA
Output	Digital RS485 MODBUS
Type of contact	Photodiode - 12 pulses/rotation

Measurements	
Mechanical Range	2-200 km/h
Average Error	0,06%
Standard deviation error	1,01%
Output	Digital RS 485 MODBUS

Mechanical Features	
Materials	Stainless Steel AISI316
Connector	M12
Weight (No cable)	700 g
Body rotor H	115mm
Body rotor + support	154mm
Size with connector M12	7,5 mm
Top body rotor min. diam.	29 mm
Top body rotor max. diam.	40 mm
Max. diam. with cups	112 mm
Storage temperature	-40 °C +85 °C
Operating temperature	-20 °C +85 °C
EMC	EN 61000-6-1:2001 EN 55022:2001, Class B
Protection	IP66

MODBUS PROTOCOL REGISTER

HOLDING REGISTER							
REGISTER ADDRESS	REGISTER ACCESS	MSB..LSB	VARIABLE NAME	TYPE	UNITS	VARIABLE DESCRIPTION	DEFAULT VALUE
1	R	(15..0)	Wind Speed	uint16	km/h	Anemometer wind speed	--
2	R/W	(15..0)	Modbus ID	uint16	--	Modbus ID	244
3	R	(15..0)	Wind direction	uint16	Angle °	Wind Vane wind direction	--
4	--	--	--	--	--	--	--
5	--	--	--	--	--	--	--
6	--	--	--	--	--	--	--
7	R/W	(15..0)	Device Sensor	uint16	--	Sensor connected to PCB (0: Anemometer / 1: Wind Vane)	1
8	R/W	(15..0)	Baudrate	uint16	BAUDS/100	Modbus baudrate (96:9600 / 192:19200)	192
9	R/W	(15..0)	Parity	uint16	--	Modbus parity (0: None / 1: Even)	1

HOLDING REGISTER							
REGISTER ADDRESS	REGISTER ACCESS	MSB..LSB	VARIABLE NAME	TYPE	UNITS	VARIABLE DESCRIPTION	DEFAULT VALUE
1	R	(15..0)	Wind Speed	uint16	km/h	Anemometer wind speed	--
2	R/W	(15..0)	Modbus ID	uint16	--	Modbus ID	244
3	R	(15..0)	Wind direction	uint16	Angle °	Wind Vane wind direction	--
4	--	--	--	--	--	--	--
5	--	--	--	--	--	--	--
6	--	--	--	--	--	--	--
7	R/W	(15..0)	Device Sensor	uint16	--	Sensor connected to PCB (0: Anemometer / 1: Wind Vane)	1
8	R/W	(15..0)	Baudrate	uint16	BAUDS/100	Modbus baudrate (96:9600 / 192:19200)	192
9	R/W	(15..0)	Parity	uint16	--	Modbus parity (0: None / 1: Even)	1

CONNECTIONS

It is possible to combine the anemometer with a master device with MODBUS protocol to view the data immediately and give alarm signals

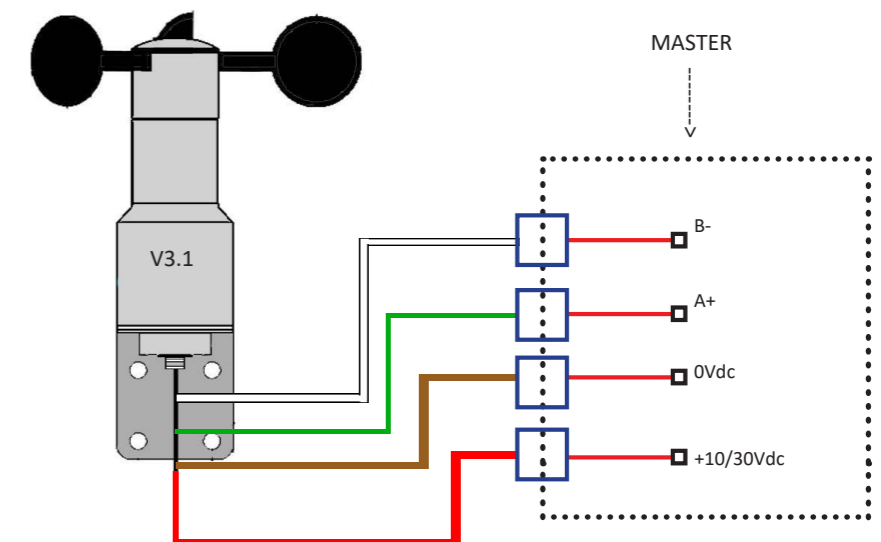
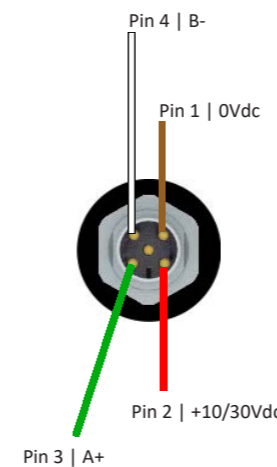

DIMENSION AND MECHANICAL FEATURES

- Mounting $\pm 3^\circ$ on vertical axis
- Cups upward
- Measurement range from 2 to 200 km/h
- Stainless steel support assembled
- IP 66 degree protection
- Operating temperature -40°C $+85^\circ\text{C}$
- Storage temperature -40°C a $+125^\circ\text{C}$
- Weight 700 g connection cable excluded
- Average error 0,06%
- Standard deviation error 1,01%
- Analisis made in a wind tunnel with a 0 to 200 km/h wind speed exceeding
- Nylon Cups Reinforced for the hail, resistant from -40°C to $+120^\circ\text{C}$, diam. 30mm, interchangeable

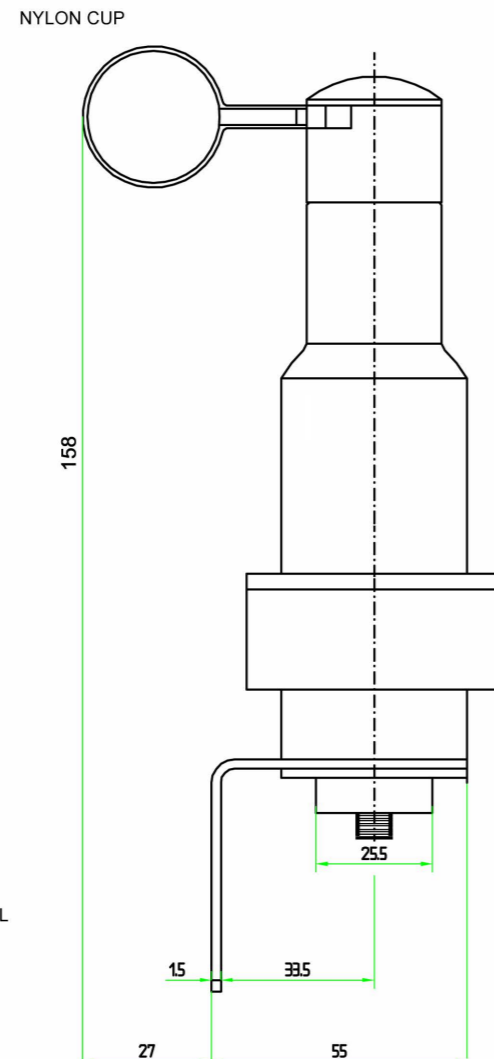
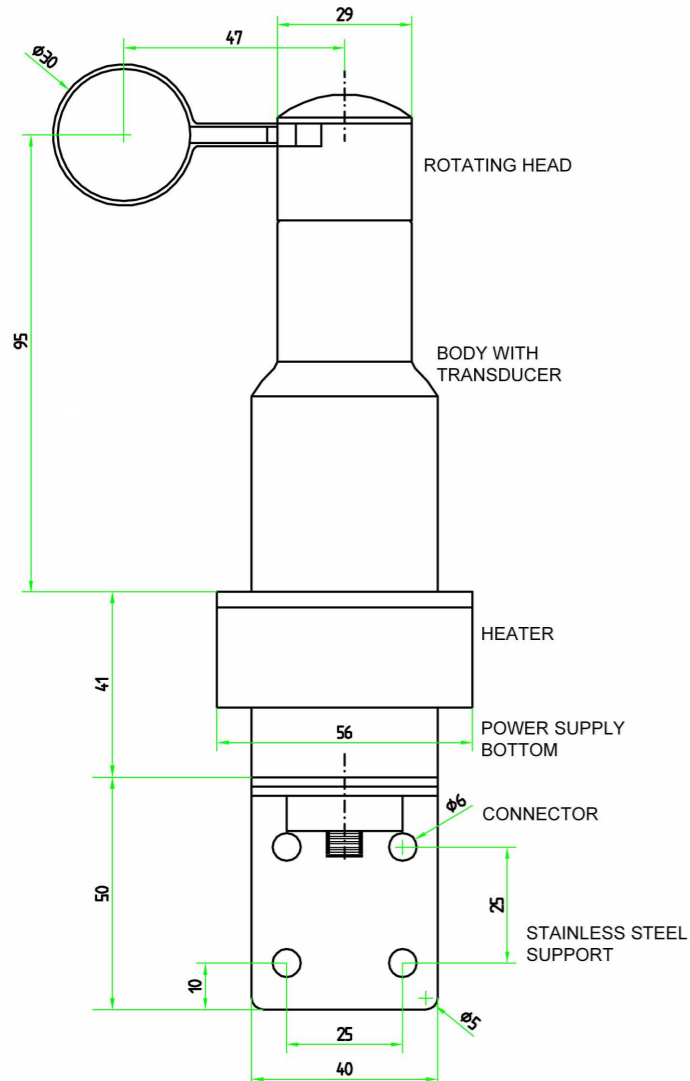

ANTC_V_R STAINLESS STEEL CONNECTION

NOTE: ANTC_V_R POWER SUPPLY MUST BE 24Vdc

CAUTION:

- **Anemometer + Heater parallel 24VDC Power supply** use shielded cable 5x0,5 sq mm - the braided shield **MUST NOT BE CONNECTED** to the ground connector but completely isolated. It should be connected to ground only from the connection to the PLC electronics, display or electronic ANTC
- **Anemometer and Heater separated Power supply** use shielded cable 5x0,5 sq mm - the braided shield **MUST NOT BE CONNECTED** to the ground connector but completely isolated. It should be connected to ground only from the connection to the PLC electronics, display or electronic ANTC

HEATER POWER SUPPLY:

- 24Vdc parallel to anemometer supply voltage if equal or more than 500 mA
- 24Vdc 24Vdc Heater to be conected on pins 2 + E with separated cable if supply voltage if less than 500 mA

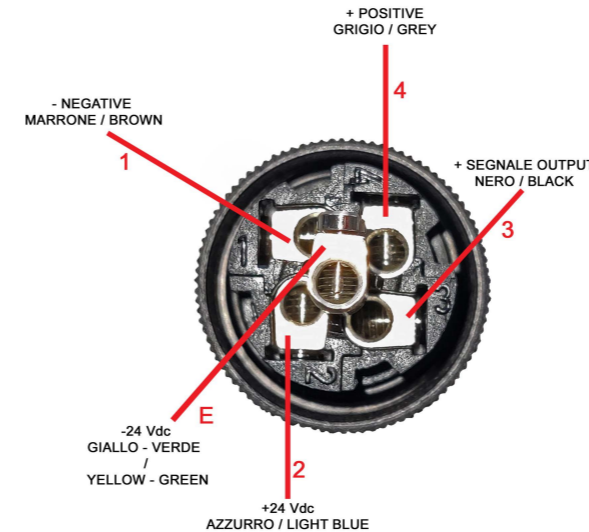

ANTC_V_R - HEATER VERSION

ANTC_V_R is an anemometer, which meets every requirement of use in electronics. Is in fact equipped with its own programmable logic. It can be used for any on-board detection of wind turbines in the presence of sources of power from batteries 24 vdc. Its output signal can be configured for pulse output, voltage output 0-5 / 1-5 / 0-10 / 2-10 Vdc, current output 0-20 / 4-20 mA or RS485 MODBUS. It can be connected through the various outputs available depending on the model directly to PLC and / or board electronic market, tachometers WM44P as the model of our product range. The body of the rotor is machined aluminum. The head rotates on ball bearings. The cups are made of nylon shock-absorbent and easily interchangeable. It also features a convenient connector for connection. The count rate is via optical transducer, a digital encoder with 12 pulses per revolution.

Complete of anti-icing HEATER.

Each anemometer is equipped with black Nylon Cups interchangeable, stainless steel support, 5 pin M12 screw jack connector.